



The **LOGLOGIC BIGTRAK** is a rugged multi-purpose tool carrier.

The low ground pressure, high ground clearance and excellent maneuverability of the LOGLOGIC BIGTRAK make it suitable for a wide range of operations in the most difficult conditions. With a wide range of possible attachments and bodies including Sprayers, Spreader, Tanks, Cranes, and Insulated access Platforms, etc. The potential applications are varied and diverse.

**FEATURES:**

- Bridgestone Rubber Track System for low maintenance and minimal damage to the highway surfaces.
- Unique patented single lever control for infinitely variable forward and reverse speed and steering.
- Two speed wheel motors for high tractive effort or high speed.
- High specification rubber mounted safety cab with suspension seat and lap restraint.
- ROPS and FOPS
- Powerful auxiliary hydraulics.
- Integral oil immersed emergency, and parking brakes.

**OPTIONS:**

- Range of cranes for various operations up to 160 kNm.
- Range of bodies for specialist applications.
- Various cab/engine positions to suit specific applications, ie Forward control. (as shown)
- Insulated boom access platforms for live power line operations working up to 46 KV.
- Front and rear linkages and PTOs for chippers, mowers etc.



**TECHNICAL DATA:**

Palfinger 12502 C Crane 12.1 mt 18.8m outreach (360 kgs) with Autoguide 50PXV Auger

**SPECIFICATIONS:**

Weight (empty).....5,980 kg  
 Payload.....5,000 kg  
 Ground Pressure (empty).....0.16 kg/cm (2.27 psi)

**ENGINE:**

Perkins 1104-DE44TA 4 Cylinder Turbocharged  
 Cubic Capacity.....4.4 lts

Maximum Power (din 70020).....95.5 kw (130 PS)  
 Maximum Torque (1600 rpm).....419 Nm  
 Fuel Tank Capacity.....175 lts (39 gals)

**TRANSMISSION:**

Transmission Pump Displacement.....2 x 64 cc/ rev 4.08 cu.in/ rev  
 Maximum Pressure.....420 bar (6100 psi)

Wheel Motor Displacement.....2 x 2099/ 1049 cc. (128/64 cu.in)  
 Tractive Effort.....9.972 kg. (9.972 tonnes)  
 Maximum Speed.....16.0 km/hr (10 mph)  
 Transmission Oil Capacity.....175 ltrs (39 gals)

**loglogic**

Peverstone  
 Cullompton  
 Devon EX15 1RW  
 Tel: 0044 (0) 1884 83 99 99  
 www.loglogic.co.uk

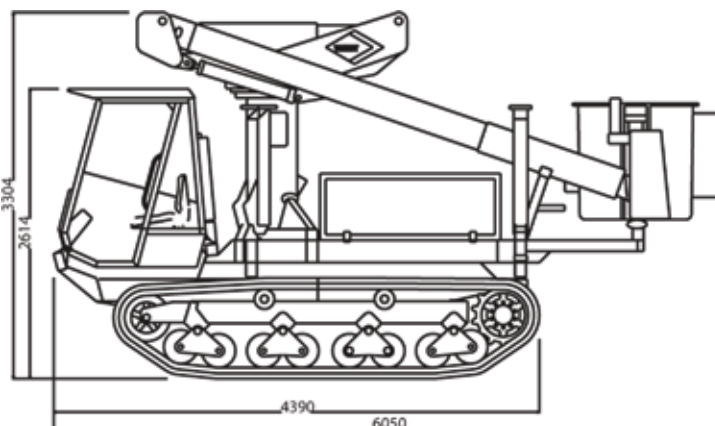

SCAN HERE